

Item Id	Name:	名称	Description
ATV-110-2S/B3-01	FRAME	车架	
ATV-110-2S/B3-02	PROTECT FRAME	保护架	
ATV-110-2S/B3-03	RUBBER GRIP	橡胶塞	
ATV-110-2S/B3-04	HEX FLANGE BOLT M8*20	螺栓法兰面M8*20	
ATV-110-2S/B3-05	LOCK NUT M8	自锁螺母M8	
ATV-110-2S/B3-06	REAR CARRIER	后货架	
ATV-110-2S/B3-07	HEX FLANGE BOLT M8*20	螺栓法兰面M8*20	
ATV-110-2S/B3-08	LOCK NUT M8	自锁螺母M8	
ATV-110-2S/B3-09	PEDAL, BRAKE	脚刹杆	
ATV-110-2S/B3-10	HEX FLANGE BOLT M8*16	螺栓法兰面M8*16	
ATV-110-2S/B3-11	PLANE WASHER $\phi$ 8*24	平垫 $\phi$ 8*24	
ATV-110-2S/B3-12	RR.BRAKE ASSY	后制动总成	
ATV-110-2S/B3-13	BRAKE SHOE	制动垫片	
ATV-110-2S/B3-14	SPRING,RR.BRAKE SWITCH	刹车开关弹簧	
ATV-110-2S/B3-15	SPRING,TENSION	脚刹开关弹簧	
ATV-110-2S/B3-16	HEX FLANGE BOLT M6*25	螺栓法兰面M6*25	
ATV-110-2S/B3-17	LOCK NUT M6	自锁螺母M6	
ATV-110-2S/B3-18	HEX FLANGE BOLTM8*16 ,FIX DISC	碟刹固定螺栓法兰面M8*16	
ATV-110-2S/B3-19	MIDDLE SPACER,BRAKE DISC	碟刹隔套	

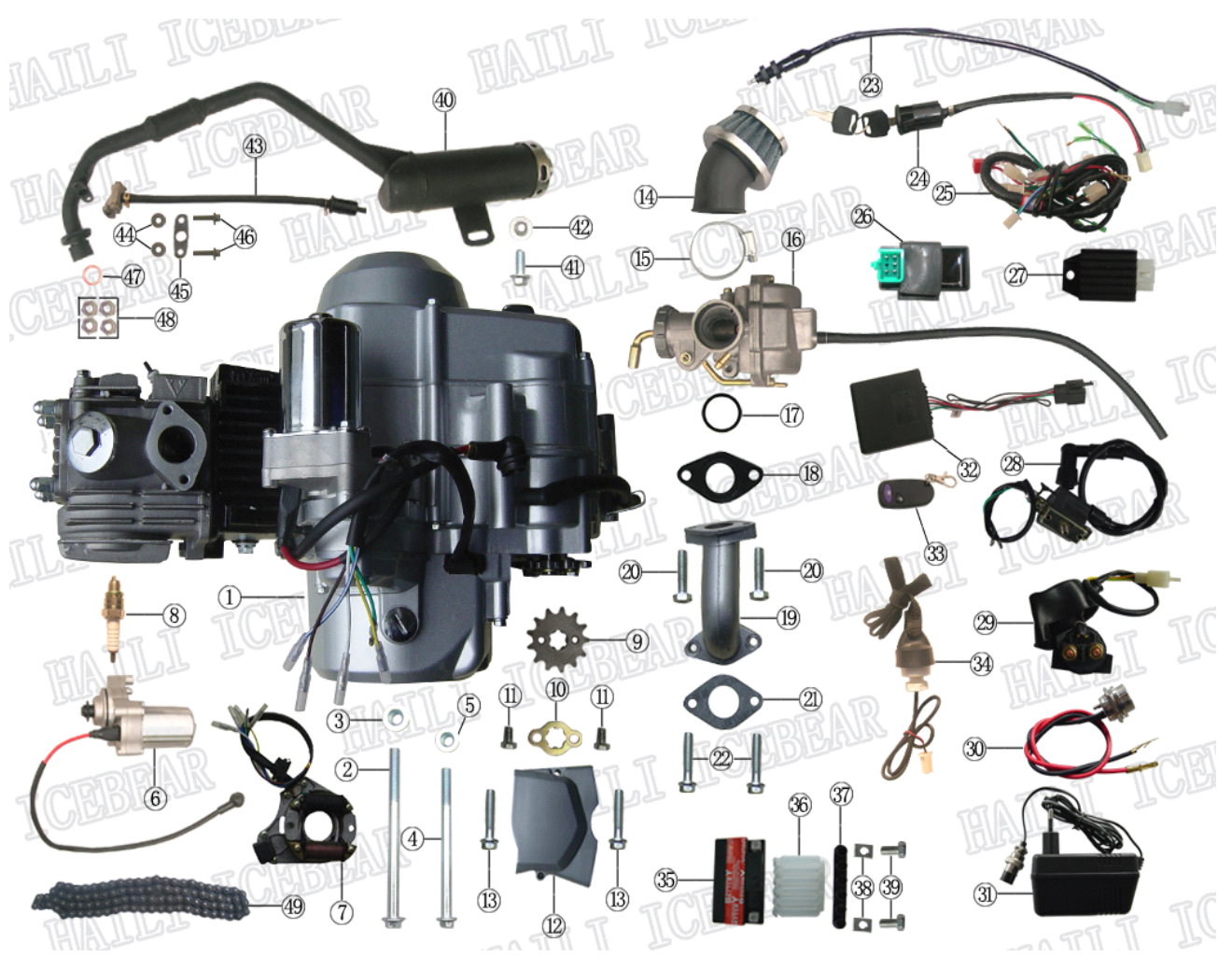

Item Id	Name:	名称	Description
ATV-110-2S/B5-01	ENGINE	发动机	
ATV-110-2S/B5-02	HEX FLANGBOLT M8*115	螺栓法兰面M8*115	

ATV-110-2S/B5-03	LOCK NUT M8	自锁螺母M8	
ATV-110-2S/B5-04	HEX FLANGBOLT M8*105	螺栓法兰面M8*105	
ATV-110-2S/B5-05	LOCK NUT M8	自锁螺母M8	
ATV-110-2S/B5-06	STARTER	启动电机	
ATV-110-2S/B5-07	GENERATOR,ENGINE	发动机磁电机	
ATV-110-2S/B5-08	SPARK PLUG A7TC	火花塞A7TC	
ATV-110-2S/B5-09	ENGINE SPROCKET 420*14	发动机链轮420*14	
ATV-110-2S/B5-10	CLIP,FR,SPROCKET	链轮卡片	
ATV-110-2S/B5-11	HEX FLANGBOLT M6*10	螺栓外六角M6*10	
ATV-110-2S/B5-12	BACKCOVER,L.CRANKCASE	发动机尾盖	
ATV-110-2S/B5-13	HEX FLANGBOLT M6*25	螺栓法兰面M6*25	
ATV-110-2S/B5-14	AIR CLEANER	空滤器	
ATV-110-2S/B5-15	AIR CLEANER HOLDER, AIR PIPE	空滤器抱箍	
ATV-110-2S/B5-16	CARBURETOR PZ20	化油器PZ20	
ATV-110-2S/B5-17	O-RING	O型圈	
ATV-110-2S/B5-18	INSULTOR, CARBURETOR	胶木垫片	
ATV-110-2S/B5-19	INTAKE PIPE XS43	进气管XS43	
ATV-110-2S/B5-20	HEX FLANGBOLT 6*20	螺栓外六角6*20	
ATV-110-2S/B5-21	GASKET, INSULATOR	纸垫	
ATV-110-2S/B5-22	HEX FLANGBOLT M6*28	螺栓法兰面M6*28	
ATV-110-2S/B5-23	FOOT BRAKE CABLE	脚刹开关	
ATV-110-2S/B5-24	IGNITION SWITCH LOCK	电门锁	
ATV-110-2S/B5-25	MAIN CABLE	主电缆	
ATV-110-2S/B5-26	IGNITER	点火器	
ATV-110-2S/B5-27	RECTIFIER	调压整流器	
ATV-110-2S/B5-28	IGNITION LOOP	高压包	
ATV-110-2S/B5-29	RELY	继电器	
ATV-110-2S/B5-30	CHARGING PORT	充电口	
ATV-110-2S/B5-31	CHARGE	充电器	
ATV-110-2S/B5-32	ALARM	防盗器	
ATV-110-2S/B5-33	REMOTE CONTROL	遥控器	
ATV-110-2S/B5-34	SAFETY SWITCH	熄火开关	
ATV-110-2S/B5-35	BATTERY	电池	
ATV-110-2S/B5-36	ELECTROLYTE	电解液	
ATV-110-2S/B5-37	BAND, BATTERY	电池密封条	
ATV-110-2S/B5-38	NUT, M6	方形螺母M6	
ATV-110-2S/B5-39	BOLT, M6*12	螺栓外六角M6*12	
ATV-110-2S/B5-40	EXHAUSTER	消声器	
ATV-110-2S/B5-41	HEX FLANGBOLT M8*20	螺栓法兰面M8*20	
ATV-110-2S/B5-42	LOCK NUT M8	自锁螺母M8	
ATV-110-2S/B5-43	AIR COLANDER ENTERWINDPIPE	二次补气阀	
ATV-110-2S/B5-44	LOCK NUT M6	自锁螺母M6	
ATV-110-2S/B5-45	WASHER	补气阀垫片	
ATV-110-2S/B5-46	BOLT, M6*25	螺栓法兰面M6*25	
ATV-110-2S/B5-47	MUFFLER AIRPROOF GASKET	消声垫圈	
ATV-110-2S/B5-48	NUT,M6	普通螺母M6	
ATV-110-2S/B5-49	CHAIN 420/76	链条420/76	

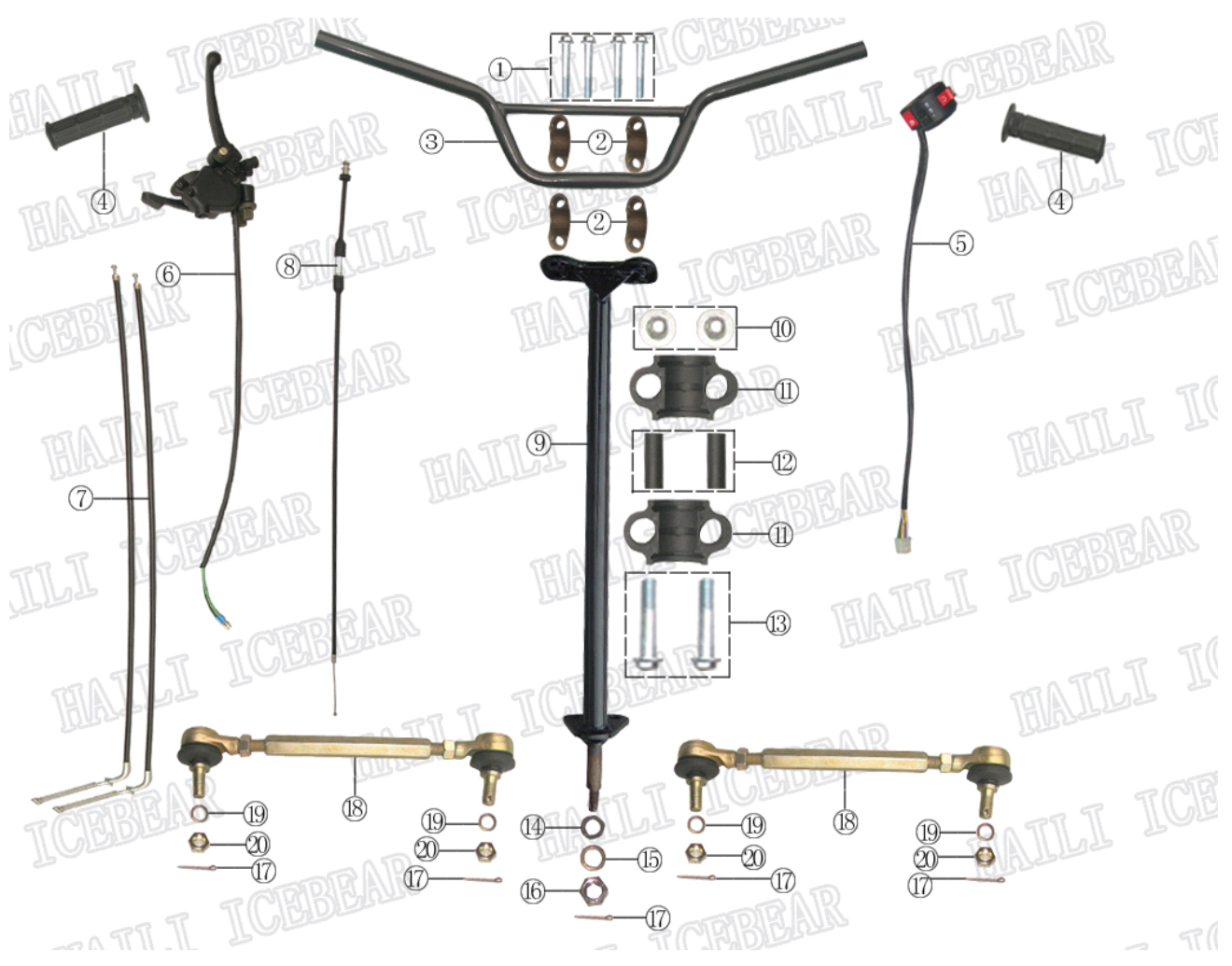

Item Id	Name:	名称	Description
ATV-110-2S/B1-01	HEX FLANG BOLT M8*55 ,COVER STEERING POLE HOLDER	手把管卡座螺栓法兰面 M8*55	
ATV-110-2S/B1-02	COVER,STEERING POLE HOLDER	手把管卡子卡座	
ATV-110-2S/B1-03	STEERING HANDLE	手把管	
ATV-110-2S/B1-04	HANDLE GRIP	手把胶套	
ATV-110-2S/B1-05	THREE FUNCTION SWITCH	三功能开关	
ATV-110-2S/B1-06	CABLE, BRAKE, THROTTLE LEVER	前刹加油手柄	
ATV-110-2S/B1-07	FR.BRAKE CABLE900*85	前制动拉索900*85	
ATV-110-2S/B1-08	THEOTTLE CABLE710*85	油门拉索710*85	
ATV-110-2S/B1-09	STEERING POLE	方向柱	
ATV-110-2S/B1-10	LOCK NUT M10,STEERING POLE HOLDER	方向柱卡座自锁螺母M10	
ATV-110-2S/B1-11	STEERING POLE HOLDER	方向柱卡座	
ATV-110-2S/B1-12	BUSH,STEERING POLE HOLDER14*39.5	方向柱卡座衬管14*39.5	
ATV-110-2S/B1-13	HEX FLANGE BOLT M10*55 ,STEERING POLE HOLDER	方向柱卡座螺栓法兰面 M10*55	
ATV-110-2S/B1-14	PLANE WASHER M10,STEERING POLE	方向柱下平垫M10	
ATV-110-2S/B1-15	PLANE WASHER M10,STEERING POLE	方向柱下弹垫M10	
ATV-110-2S/B1-16	CONCAVE NUT M10 , STEERING POLE	方向柱下开槽螺母M10	
ATV-110-2S/B1-17	SPLIT PIN 25*20 ,STEERING POLE	方向柱下开口销2.5*20	
ATV-110-2S/B1-18	TURNING SHAFT L=120MM	转向拉杆L=120mm	
ATV-110-2S/B1-19	ELASTICITY WASHER M10,TURNING SHAFT	转向拉杆弹垫M10	
ATV-110-2S/B1-20	CONCAVE	转向拉杆开槽螺母M10	



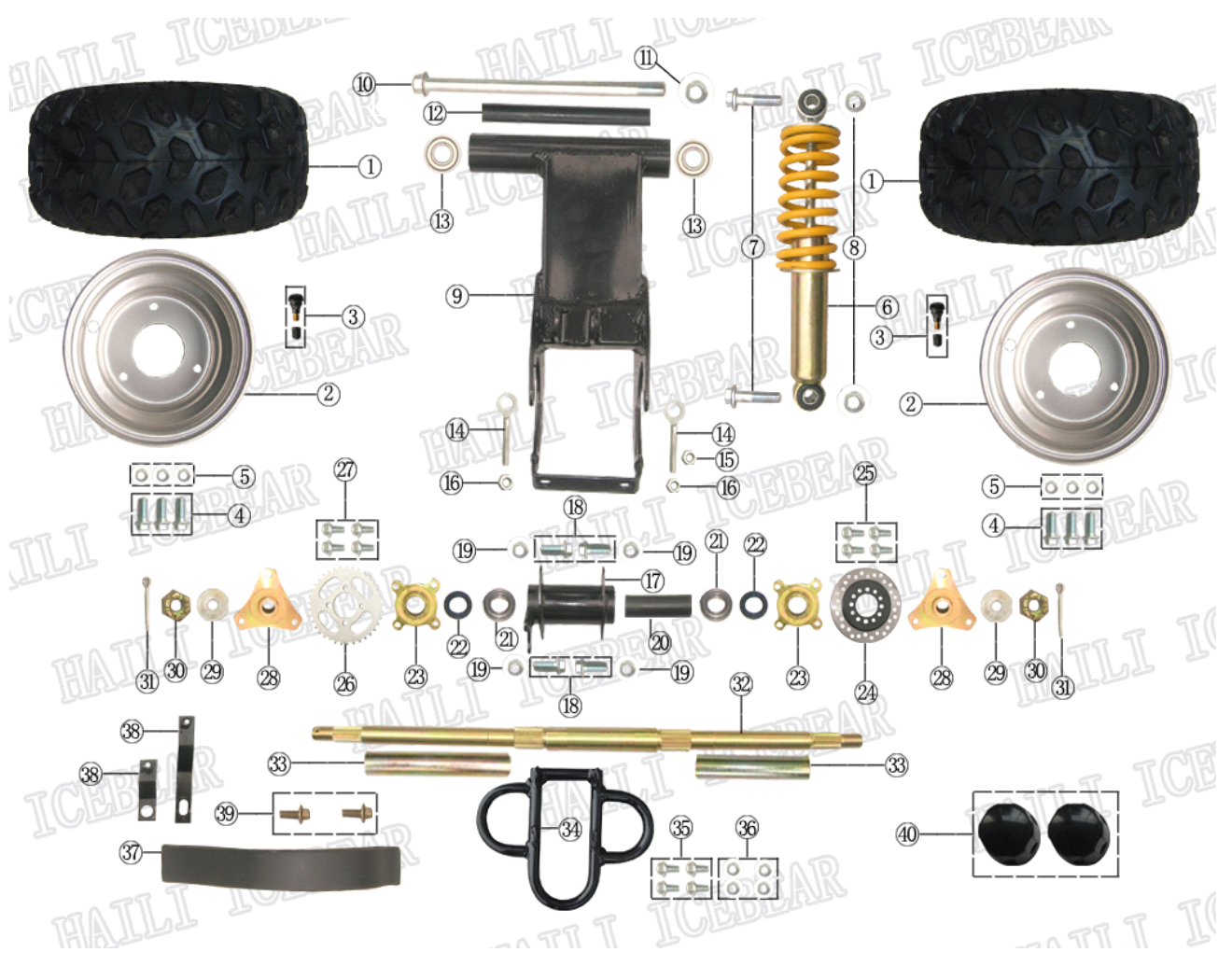

Item Id	Name:	名称	Description
ATV-110-2S/B4-01	RR.TIRE145/70-6	后轮胎145/70-6	
ATV-110-2S/B4-02	RR.RIM 6"	后轮毂6寸	
ATV-110-2S/B4-03	VALVE, RIM	冲气嘴	
ATV-110-2S/B4-04	HEX FLANG BOLT M8*20	螺栓法兰面M8*20	
ATV-110-2S/B4-05	LOCK NUT M8	自锁螺母M8	
ATV-110-2S/B4-06	RR.SHOCK ABSORBER 250MM	后减震250mm	
ATV-110-2S/B4-07	BOLT M10*40	螺栓法兰面M10*40	
ATV-110-2S/B4-08	LOCK NUT, M10	自锁螺母M10	
ATV-110-2S/B4-09	RR.SWING ARM	后平叉	
ATV-110-2S/B4-10	RR SWING ARM SHAFT M12*195	后叉轴M12*195	
ATV-110-2S/B4-11	LUCK NUT M10	自锁螺母M10	
ATV-110-2S/B4-12	BUSH,RR.SWING ARM	后平叉衬管	
ATV-110-2S/B4-13	BEARING 6001	轴承6001	
ATV-110-2S/B4-14	ADJUSTER,CHAIN	链条调节器	
ATV-110-2S/B4-15	NUT M8	普通螺母M8	
ATV-110-2S/B4-16	SKID PROOF NUT M8	防松螺母M8	
ATV-110-2S/B4-17	REAR AXLE ASSY	后桥箱	
ATV-110-2S/B4-18	HEX FLANG BOLT M10*25	螺栓法兰面M10*25	
ATV-110-2S/B4-19	LOCK NUT M10	自锁螺母M10	
ATV-110-2S/B4-20	BUSH	后桥箱衬管	
ATV-110-2S/B4-21	BERAING 6205	轴承6205	
ATV-110-2S/B4-22	OIL SEAL 35*52*8	油封35*52*8	
ATV-110-2S/B4-23	BRAKE DISC STAY	链.碟盘座	
ATV-110-2S/B4-24	RR.BRAKE DISC $\phi$ 160mm	后制动盘 $\phi$ 160mm	
ATV-110-2S/B4-25	HEX FLANG BOLT M8*16	螺栓法兰面M8*16	
ATV-110-2S/B4-26	RR.SPROCKET 420/37	后链轮420/37	
ATV-110-2S/B4-27	HEX FLANG BOLT M8*16	螺栓法兰面M8*16	
ATV-110-2S/B4-28	BOSS	后轮座	
ATV-110-2S/B4-29	DUST ROOF	防尘盖	
ATV-110-2S/B4-30	CONCAVE NUT M16	开槽螺母M16	
ATV-110-2S/B4-31	SPLIT PIN3.2*30	开口销3.2*30	
ATV-110-2S/B4-32	RR.AXES	后轴610mm	
ATV-110-2S/B4-33	COLLAR	后桥左右套管	
ATV-110-2S/B4-34	COVER	后桥保护架	
ATV-110-2S/B4-35	HEX FLANG BOLT M8*20	螺栓法兰面M8*20	
ATV-110-2S/B4-36	LOCK NUT M8	自锁螺母M8	
ATV-110-2S/B4-37	CHAIN COVER	后链罩	
ATV-110-2S/B4-38		后链罩长短片	
ATV-110-2S/B4-39	HEX FLANG BOLT M6*12	螺栓法兰面M6*12	
ATV-110-2S/B4-40	DUST COVER	防尘罩	



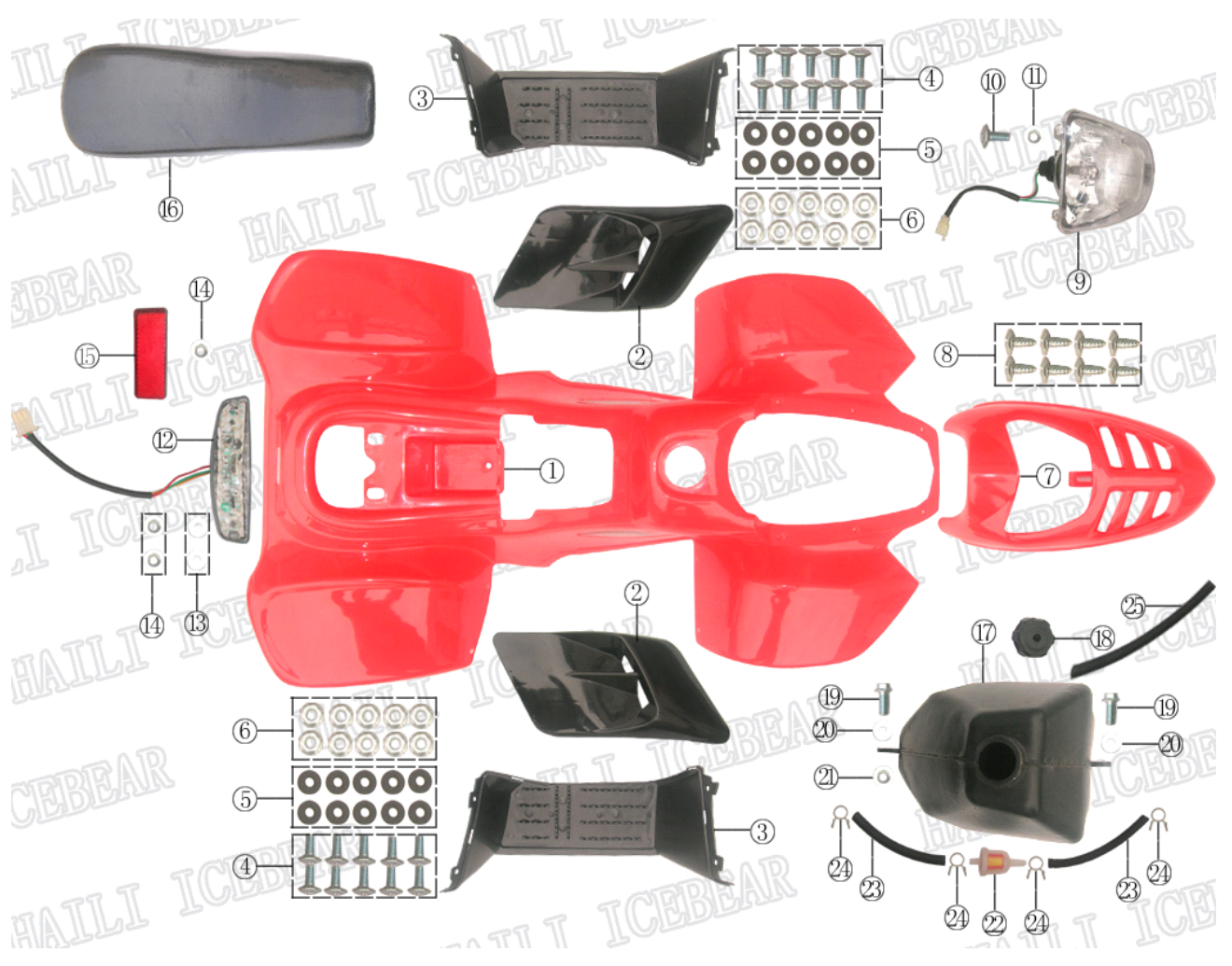

Item Id	Name:	名称	Description
ATV-110-2S/B6-01	PLASTICS ASSY	塑料件主体	
ATV-110-2S/B6-02		左右侧板	
ATV-110-2S/B6-03	R.L. FOOTREST	左右脚踏板	
ATV-110-2S/B6-04	CROSS BALL-SHAPE HEAD BOLT M6*16	十字大扁头M6*16	
ATV-110-2S/B6-05	RUBBER WASHER $\phi 6$	橡胶垫 $\phi 6$	
ATV-110-2S/B6-06	LOCK NUT M6	自锁螺母M6	
ATV-110-2S/B6-07	HEAD COVER	前头罩	
ATV-110-2S/B6-08	BOLT M4*14	自攻丝M4*14	
ATV-110-2S/B6-09	FR.LIGHT	前大灯	
ATV-110-2S/B6-10	CROSS BALL - SHAPE HEAD BOLT	十字大扁头M6	
ATV-110-2S/B6-11	LOCK NUTM6	自锁螺母M6	
ATV-110-2S/B6-12	TAIL LIGHT	后尾灯	
ATV-110-2S/B6-13	PLANEWASHER $\phi 6 \times \phi 18$	平垫 $\phi 6 \times \phi 18$	
ATV-110-2S/B6-14	LOCK NUT M6	自锁螺母M6	
ATV-110-2S/B6-15	REFLECTOR	反光片长方形红色	
ATV-110-2S/B6-16	SEAT	坐垫	
ATV-110-2S/B6-17	GAS TANK	油壶	
ATV-110-2S/B6-18	GASTANK CAP	油壶盖	
ATV-110-2S/B6-19	HEXFLANGEBOLTM6*20	螺栓法兰面M6*20	
ATV-110-2S/B6-20	PLANEWASHER $\phi 6 \times 18$	平垫 $\phi 6 \times 18$	
ATV-110-2S/B6-21	LOCK NUT M6	自锁螺母M6	
ATV-110-2S/B6-22	GAS FILTER	汽油过滤器	
ATV-110-2S/B6-23	FUEL PIPE	油管	
ATV-110-2S/B6-24	PIPE FASTENER	油管卡簧	
ATV-110-2S/B6-25	AIR PIPE	空气管	

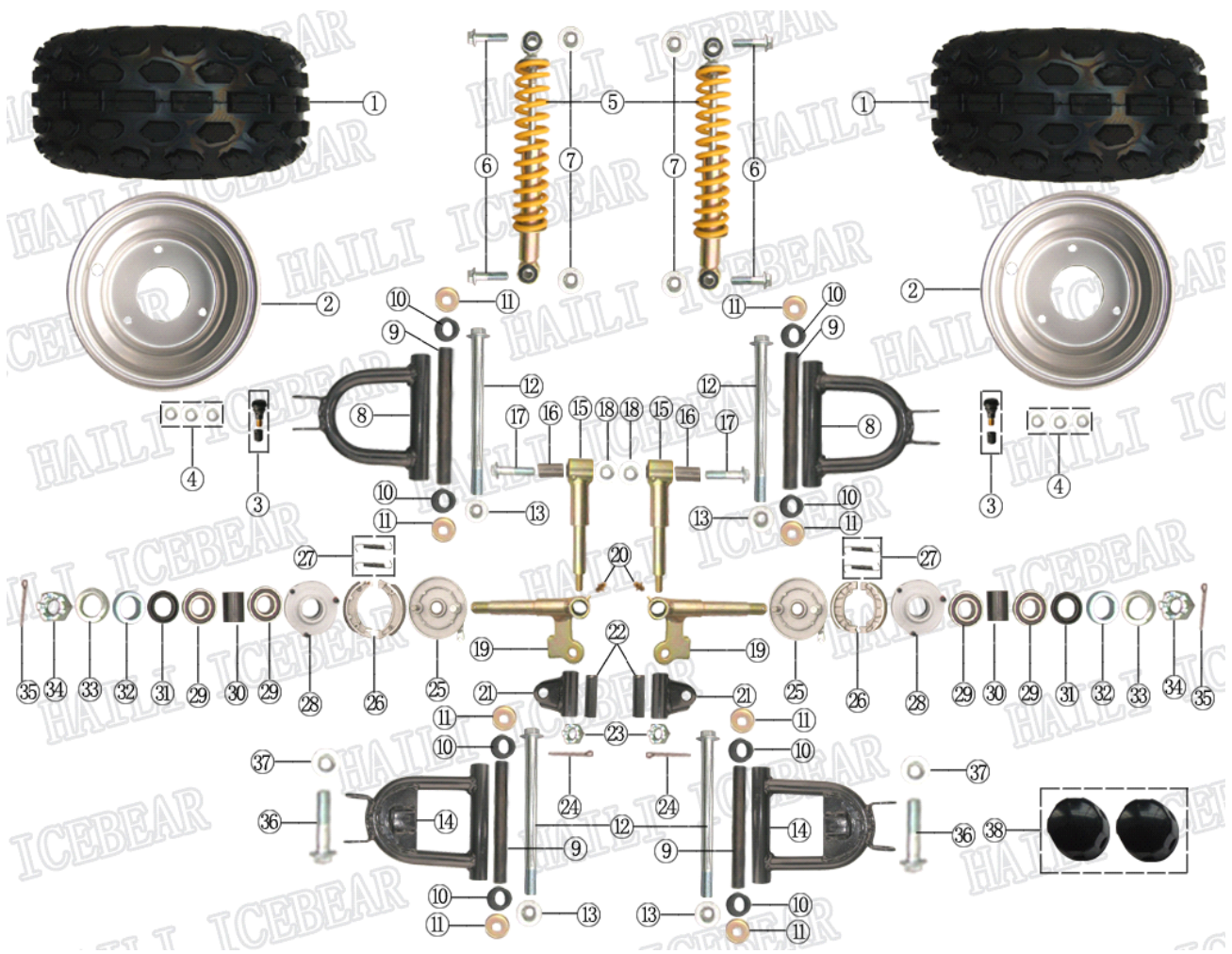

Item Id	Name:	名称	Description
ATV-110-2S/B2-01	FR. TIRE145/70-6	前轮胎145/70-6	
ATV-110-2S/B2-02	FR. RIM	前轮毂6寸	
ATV-110-2S/B2-03	AIR VALVE	气门嘴	
ATV-110-2S/B2-04	LOCK NUT M8	自锁螺母M8	
ATV-110-2S/B2-05	FR. SHOCK ABSORBER 270mm	前减震270mm	
ATV-110-2S/B2-06	HEXFLANGEBOLTM10*40	螺栓法兰面M10*40	
ATV-110-2S/B2-07	LOCKNUTM10	自锁螺母M10	
ATV-110-2S/B2-08	FR. UPRER SWINGARM	前摇架上	
ATV-110-2S/B2-09	BUSH, SWINGARM	摇架衬管	
ATV-110-2S/B2-10	NYLON,COVER	尼龙胶套	
ATV-110-2S/B2-11	DUSTCOVER	防尘盖	
ATV-110-2S/B2-12	HEXFLANGEBOLT M10*175	螺栓法兰面M10*175	
ATV-110-2S/B2-13	LOCKNUT M10	自锁螺母M10	
ATV-110-2S/B2-14	FR. LOWERSWINGARM	前摇架下	
ATV-110-2S/B2-15		主销轴	
ATV-110-2S/B2-16	COLLAR, DISTANCE M10*23*31	缓冲套M10*23*31	
ATV-110-2S/B2-17	HEXFLANGEBOLT M10*55	螺栓法兰面M10*55	
ATV-110-2S/B2-18	LOCKNUT M10	自锁螺母M10	
ATV-110-2S/B2-19	STEERING KNUCKLE ASSY(R.L)	转向节左右	
ATV-110-2S/B2-20		黄油嘴	
ATV-110-2S/B2-21		摇架连接块	
ATV-110-2S/B2-22		连接块衬管	
ATV-110-2S/B2-23	CONCAVE NUT M10*1.5	开槽螺母M10*1.5	
ATV-110-2S/B2-24	SPLIT PIN2.5*20	开口销2.5*20	
ATV-110-2S/B2-25	PLATE, BRAKE SHOE	前制动摇壁盘	
ATV-110-2S/B2-26	BRAKE SHOE SET	前制动蹄块	
ATV-110-2S/B2-27	SPRING, TENSION	蹄块拉簧	
ATV-110-2S/B2-28		前制动转体	
ATV-110-2S/B2-29	BEARING6003	轴承6003	
ATV-110-2S/B2-30	COLLAR	衬管	
ATV-110-2S/B2-31	OILSEAL	油封	
ATV-110-2S/B2-32		制动器边套	
ATV-110-2S/B2-33	RING M14	弹垫M14	
ATV-110-2S/B2-34	CONCAVE NUT M14	开槽螺母M14	
ATV-110-2S/B2-35	SPLIT PIN2.5*20	开口销2.5*20	
ATV-110-2S/B2-36	HEXFLANGEBOLTM10*70	螺栓法兰面M10*70	
ATV-110-2S/B2-37	LOCK NUTM10	自锁螺母M10	
ATV-110-2S/B2-38	DUSTCOVER	防尘罩	